

Directions for 20x10x10 Pro Supreme Golf Net and Frame

A	3-Way Corner	6
B	2-Way Corner	2
C	4-Way Corner	2
D	3-Way Tee Corner	2
E	Baffle Tee	2
F	10' pieces of 1" EMT (Lowe's-72715 Home Depot-580015)	19
G	Golf Net	1
H	Golf Baffle	1
I	Golf Target	1

Please review the parts that you received on the pallet that your frame is on to be sure that you have all the parts.

For these instructions the "back" of the cage is the side that the baffle hangs parallel to. The "front" is the side that does not have a pole at the bottom

- Lay out** the four top 3-Way Corners (A) into a ~20'x10' rectangle. Place the 4-Way Corners C half way between on the 20' side. Lay the EMT (F) between the corners.
- Prepare the poles** by sliding the Baffle Tees (C) onto opposing EMT poles (F). Make sure the eyebolts are facing up. Also, lay another piece of EMT (F) between the Baffle Tees (E).
- Assemble the top** by inserting the poles into the Corners (A). Start with one of the poles with a Baffle Tee (E), and slide the corners over each side. Make sure the corners point down and in. Now slide the pole and corner that is in line with the one you have been working with. Now move on to the poles that are perpendicular to the Baffle Tee (E) pole. Insert all 3 poles into the Corners (A) and the Baffle Tee (C). Slide on the final two corners and place the remaining EMT (F) with the Baffle Tee (C) into those corners. You should now have a closed square with a pole in the middle.
- Tighten the Corners** (A & C) onto the EMT (F). Hand tightening should be sufficient, it is just supposed to keep the poles from sliding. Do not tighten the 2 Baffle Tee (E) eyebolts on the outside pipe. This will allow you to easily adjust your baffle location.
- Attach the Legs** by inserting 6 pieces of EMT (F) into the Corners (A & C). Tighten the Corners (A & C) onto the EMT (F) legs.
- Attach the bottom Corners** (A, B & D) to the leg EMTs (F) you just secured. Make sure the 2-Way Corners are at the front, opposite the baffle and pointing towards the rear. And the 3-Way Tee Corners (D) are directly below the 4-Way Corners (C)
- Connect the corners** with the remaining 3 pieces of EMT (F). Tighten the corners onto the pipes.
- Lay out your net** (G) inside the frame. Find the 2 s-hooks with red tabs, that is the top, front of the net. The other color signifies the top back of the net. The support rope along the top sides should be on the bottom.
- Hang your net** (G) by hooking the s-hooks through the rings on the corners.
- Attach your baffle** (H) to the cross bar. Adjust the distance of the cross bar from the back of the net to your desired position and feed the toggles through the net and attach them to the baffle.
- Attach your target** (G) in front of the baffle. Let the bottom of the target hang loose to prolong life.

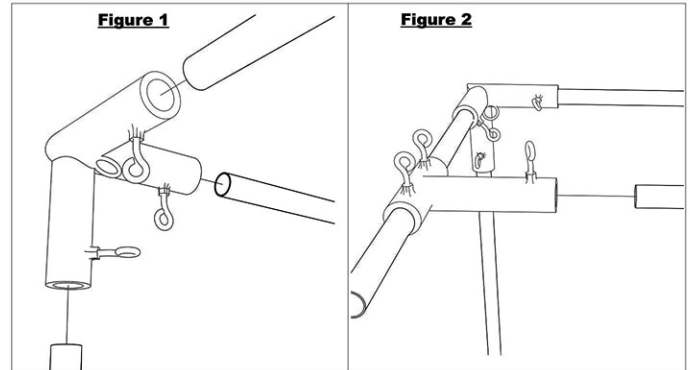

Exploded View

